

Multi-Purpose Space Tug Vehicle

John W. Robinson¹

Propellant Supply Technology, Seal Beach, California, 90740

Russel E. Rhodes (ret.)²

Kennedy Space Center, Florida, 32899

Robert S. Bell³

Robert Bell and Associates, Highlands Ranch, Colorado 80129

Abstract

The reusable Multi-Purpose Space Tug will satisfy earth orbit transfer functions for necessary space infrastructure development and provide a technology demonstrator to support flight hardware qualification for propulsion components for future on-orbit, moon and planetary operations. Previous studies by the SPST has provided insight to aid in the Space Tug design employing choices consistent with expected architecture requirements and goals⁽¹⁾. There are many alternatives and choices to produce a system that best meets the performance requirements, but at the same time provides the best opportunity of reaching all the required objectives. The purpose of the Space Tug orbital maneuvering vehicle is to provide a vehicle with long term in-space operation with the capability to interact with necessary architecture elements providing a test bed to demonstrate long term operation and qualification of propulsion hardware for future in-space propulsion needs and be a workhorse element in the infra-structure development.

The Space Tug will perform its functions and also provide a test bed to evaluate needed propulsion related technology demonstration and qualification for long term operations for future missions. Propellant transfer with repeated on orbit refueling will be one of the key requirements to demonstrate.

I. Nomenclature

ACS - Attitude Control System	IVHM - Integrated Vehicle Health Management
EMA - Electro Mechanical Actuator	Lbf - Pounds force
ETO - Earth-to-Orbit	LCC Life Cycle Cost
DDT&E - Design, Development, Test and Evaluation	LEO - Low earth orbit
DTAL – Dual Thrust Axis Lander	LH2 - Liquid Hydrogen
GEO - Geosynchronous Earth Orbit	LOX - Liquid Oxygen
GLOW - Gross Lift Off Weight	NBP - Normal Boiling Point
GN2 - Gaseous Nitrogen	NSDD - National Security Decision Directive
GSE - Ground Support Equipment	RCS - Reaction Control System
H2 - Hydrogen	RLV - Reusable Launch Vehicle
He - Helium	SPST - Space Propulsion Synergy Team
IDBM-international Docking and Berthing Mechanism	TRL - Technology Readiness Level
Isp - Specific Impulse	TVC - Thrust Vector Control

¹Propellant Supply Technology; chairman, Space Propulsion Synergy Team, and AIAA Associate Fellow.

²Aerospace Technologist, NASA Kennedy Space Center, retired, and AIAA Senior Member.

³Private Consultant, Liquid Propulsion Technical Committee Member and AIAA Associate Fellow.

I. Introduction

This paper will address the overall design concept of a Multi-Purpose Space Tug and the initial conceptual description of the propulsion subsystem. The ultimate goal is to meet long term space objectives⁽²⁾. Future planned papers will address the overall vehicle including Structures & Materials, Guidance & Control, Design Mechanisms & Docking, Power and Communications, Test Component Installation, and Instrumentation. The SPST Functional Requirements sub-team has drawn on the knowledge, expertise, and experience of its members to develop insight that will effectively aid the architectural concept developer in making the appropriate choices consistent with the architecture goals. This data helps identify many selected choices, and, more importantly, presents the collective assessment of this sub-team's "pros" and "cons" of these choices⁽¹⁾. Many of the selected design features spelled out with "pros" and the "cons" of the propulsion system choices are presented in six major groups.

A. KEY CONCEPTUAL DESIGN REQUIREMENTS

B. SYSTEM INTEGRATION

C. NON-CHEMICAL PROPULSION

D. CHEMICAL PROPULSION

E. FUNCTIONAL INTEGRATION

F. PROPULSION THERMAL MANAGEMENT

II. Key Concepts, Definitions, and Background

The Space Tug takes basic design elements from previous flown systems, but its technology and capability are more advanced. It is designed to support 20 year life and long-duration space missions including up to 30 days active maneuver time plus 12 month's quiescent mode. This will require adaption of on-orbit propellant and pressurant resupply for all required fluids needed to operate the Space Tug. The spacecraft's engine, adaptor, thermal protection and avionics systems are designed to be upgradeable as new technologies become available.

The vehicle will be constructed of advanced materials, like aluminum-lithium (Al/Li) alloy used on the shuttle's external tank and composite carbon materials used on the Delta IV and Atlas V rockets. The Space Tug itself will be insulated as required to support long term storage including Thermodynamic Vent Systems (TVS), internal and external insulation schemes, vapor cooled shields, micrometeoroid shielding, etc. To allow Space Tug to mate with other vehicles, it will be equipped with a docking device similar to the APAS-95 docking mechanism or other commercial/international variants, such as the International Docking and Berthing Mechanism (IDBM).

Future missions could include exploration of a near Earth asteroid, moon based support trips and return safely to Earth. Congressional budgetary allocations and the long-range plans of NASA have since both been written/rewritten to conform to these two long range presidential mandates. This most recent change in NASA's long range objectives notably omitted the earlier intermediary objective of the establishment of a moon base first (which had been included in the now cancelled Constellation program). The potential of the near-term establishment of a moon-base via a privately funded venture, or via the space programs of other nations remains a possibility. Exploration of a near Earth asteroid, place an asteroid in lunar orbit, rather than sending astronauts to an asteroid in deep space is being considered. All in all, there is no clear plan, however, the SPST has been developing a Roadmap for Long Term Sustainable Space Exploration and Habitation, which consists of an all in-space-based architecture. This vehicle is an early entry in the all space-based hardware and will be a tool in the development of future "in-space based systems and architecture".

The Multi-Purpose Space Tug Vehicle is intended to do a variety of functions in support of the overall space architecture and to provide a means of docking with the ISS and other elements as needed providing an in-space development platform while the in-space architecture evolves. Many requirements and design features will be derived from the topics listed below:

- A. **Key Conceptual Design Requirements:** Focused on the overall mission capabilities, what is the performance expectations for the unit?
- B. **System Integration Approach:** *Focused on the requirement for safety, reliability, dependability, maintainability, operability and low life cycle cost (LCC).*
- C. **Non-Chemical Propulsion:** *Focused on choice of propulsion type. (Not chosen for Space Tug, however, could provide test-bed for components for other future needed architecture elements)*
- D. **Chemical Propulsion:** *Focused on propellant choice implications.*
- E. **Functional Integration:** *Focused on the degree of integration of the many propulsive and closely associated functions, and on the choice of the engine combustion power cycle.*
- F. **Thermal Management:** *Focused on tank insulation and overall vehicle design and integration. Each of these groups is further broken down into subgroups, and at that level the consensus pros and cons are presented. The intended use of this paper is to provide a resource of focused material for architectural concept developers to use in designing new advanced systems including college design classes. It is also a possible source of input material for developing a model for designing and analyzing advanced concepts to help identify focused technology needs and their priorities. It is important to remember that the information presented should be considered independently and the Pros and Cons might vary when considered in combinations.*

A. KEY CONCEPTUAL DESIGN REQUIREMENTS

1. *In-space earth proximity pollution free environment.*
2. *Long term reusable in-space operation.*
3. *On-orbit fuel transfer for sustained operation.*
4. *Cargo/Payloads to required orbits based on mission needs.*
5. *Test-bed for propulsion hardware for long in-space architecture components. Perform flight qualification on hardware for future in-space needs.*
6. *LOX/Hydrogen main propellant with long duration storage.*
7. *20 year continuous in-space life with refueling capability.*
8. *Five year life without need to refuel as a goal.*
9. *Space Tug operating subsystem built with provision for on-orbit upgrades incorporated into design*

B. SYSTEM INTEGRATION

System integration considers seven main areas concerning the propulsion system that meet the prime objectives:

1. *Vehicle configuration and propellant tanks which concerns the placement of the tanks such as Lox tank aft or forward, parallel tanks, toroidal tanks, concentric, etc.*
2. *Propulsion system engine propellant feed technique concerning pressure-fed versus pump-fed and what type of pump.*
3. *Propellant transfer pumps location area which discusses where the pumps might be placed.*

4. Functionally optimizing propulsion components versus traditional stand-alone rocket engine area. How many turbopump sets should be associated with how many thrust chamber assemblies.
5. Main rocket engine start considerations, selecting the best engine start methods.
6. Rocket engine ignition system and best ignition method.
7. Number of main rocket nozzles and their placement.

C. PROPELLANT AND PROPULSION

Propellant and propulsion focus on four areas:

1. Choice of propellant type such as cryogenic, storable non-toxic and toxic, solids, and hybrids.
2. Choice of propellant by density or performance consideration including mixture ratio shifts, slush and gelled propellant focused on the prime attribute objectives.
3. Fuel versus oxygen cooling.
4. The fourth area presents monopropellant versus bipropellant system discussions and compares their pros and cons.

Discussion of other propellant and propulsion options and considerations: such as density and impulse performance. Figure 1. will provide aid in that choice.

2. Choice of Propellant by Density or Performance Considerations

A quick overview of the relative comparison of hydrocarbon fuel versus hydrogen, some with oxygen, hydrogen peroxide, and nitrogen tetroxide as the oxidizer, is shown below.

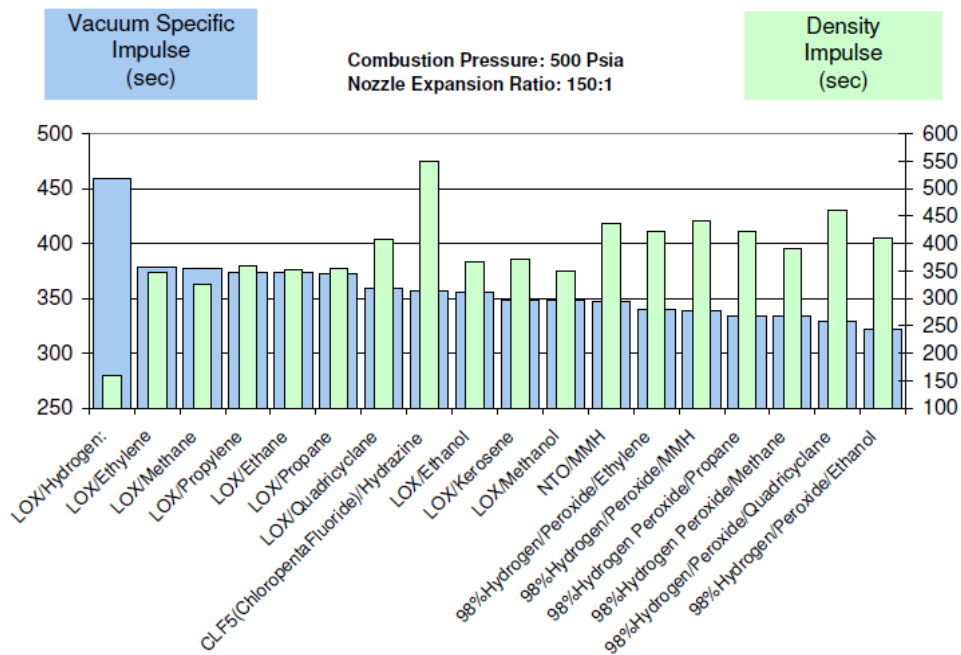

Figure 1. Propellant Choices

D. FUNCTIONAL INTEGRATION CONSIDERATIONS

Choice of propellant type such as cryogenic, storable non-toxic and toxic, solids, and hybrids or monopropellant have been traded and a baseline propellant choice using cryogenic LOX/LH2 propellant has been

selected. This trade included determining the combustion cycle. There are four combustion cycles to choose from: Staged Combustion Cycle driven by performance efficiency, but limited by dependability demonstrated; Expansion Cycle driven by long life/dependability, but limited by size demonstrated; Gas Generator Cycle driven by simplicity and size flexibility, but limited by long life demonstrated; Pulse Detonation Combustion driven by less hardware and higher thrust to weight, but no flight experience. The attributes desired for this application gives considerable focus on the expansion cycle to achieve long life and dependability.

E. THERMAL MANAGEMENT CONSIDERATIONS

The major choice here is the selection of traditional integral tank/structure or tankage with an aero-shell.

The choice of tanks and option to accommodate tank change-out for servicing in space during mission turnaround operations vs. fluid transfer will be considered for all liquid commodities.

The choice of using integral tank/structure eliminates the safety requirement to monitor and control entrapped areas caused by separate tank and shell design, eliminates extensive purging requirements, eliminates safety concerns, less systems, and will result in an overall lighter design, e.g., increased performance. However, this solution will require propellant transfer in space during mission turnaround operations.

With the cryogenic propellant, there is a choice to be made of using internal or external insulation. There is limited experience using internal insulation on the SIV and SIVB stages of the Saturn vehicle which was an expendable design. However, experience is also limited for external insulation with respect to bonding issues from thermal cycles.

III. Overall Mission Support Requirements

The Space Tug is designed to support future in-space architecture elements and missions to send spacecraft to the MOON, VENUS, ASTEROIDS and MARS both un-manned and manned. The Space Tug will provide Orbital Maneuvering Propulsion (insertion/circularization, de-orbit & Trans-lunar/mars injection) and Reaction Control Propulsion; and provide for the following functions: fill & drain; on-board propellant storage; cryogenic on-board propellant and hardware conditioning for engine start; on-board purge; pressurization; tank feed; fluid pump/pressure transfer; combustion; propellant inlet/intake management; nozzle exhaust gas management; propellant management (residuals, fuel bias, margins); engine start; engine shutdown; propellant flow and thrust interaction control (pogo suppression); anti-geysering control; propellant acquisition/settling; propellant/hardware thermal management; engine control & health management; propulsion power generation; and hardware contamination/flush for start/restart if required.

A. THERMAL ENERGY MANAGEMENT

Provide thermal management (heating & cooling) from Earth orbit to Lunar, Mars, Venus, asteroids orbits or during return and provide for the following functions: thermal energy supply (source); thermal energy transport/management within the element; thermal energy storage/accumulation to capture peak loads; thermal energy transport/distribution to user/disposition functions; and thermal energy use or dissipation.

B. OPERATIONAL SUMMARY

Requirements for the space ground node and the spaced based reusable flight elements have been identified and it seems logical that establishing the in-space architecture would be the next near term tasks for developing the human habitation of space to allow the affordable exploration of space. This capability will provide the infrastructure necessary for the commercial expansion of space activities that will close the business case. The requirements are quite extensive and the purpose of providing the Space Tug is to support all the architectural elements as they evolve. The Space Tug will be a working vehicle and have access to develop and qualify future hardware in a long term space environment. Many important shuttle upgrades could not be implemented due to

manned presence and associated risk prohibited by demanding safety issues imposed. With in-space propellant transfer, we intend to maintain the Space Tug in continual operation for many years with docking provisions to a space ground node or space station for maintenance and servicing on-orbit until new architecture elements to provide similar services come on-board. A broad range of missions will evolve with many destinations as shown below.

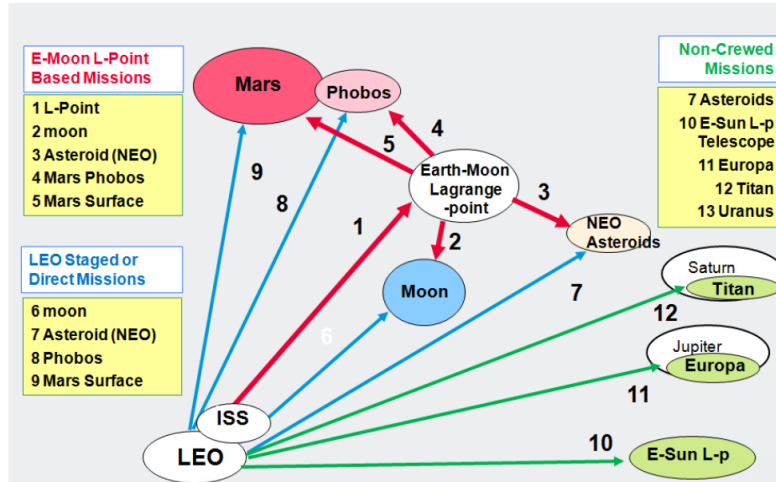

Figure 2. Possible Mission locations

In-space missions cover a wide range with destinations for many reasons and become missions that the Space Tug can support. In order to establish Space Tug vehicle requirements, selected missions and required delta-v must be reviewed and defined. Then the limiting requirements will set the design requirements for propulsion. For example

Mission 1: Conduct roundtrip mission, to perform an unmanned maintenance capsule to the Moon and return

Mission 2: Conduct roundtrip mission, to perform an unmanned maintenance support mission to refuel a satellite in GEO or replace satellite components as a solar array.

Mission 3: Conduct roundtrip mission to a high Earth orbit to deliver a satellite

Many studies were performed in the 1980-90's and requirements and design mission ΔV 's were identified. Design Mission ΔV 's broken down into typical mission segments as illustrated in Figure 3 below.

Mission Segment	RCS (mps)	Main Engine (mps)
Separation from docking station		
Phasing Orbit Injection		
Etc, etc, etc		
Total		

Figure 3. Sample Mission Requirements

III. Optional Space Tug Vehicle Designs

As earlier stated, the Multi-Purpose Space Tug has a number of subsystem elements that form the integrated vehicle configuration. Figure 4 indicates those elements with a concentration on the Propulsion Design elements for the paper.

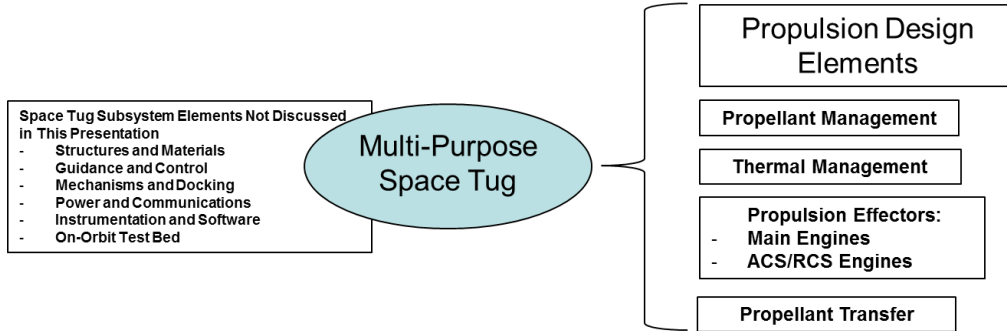

Figure 4. Space Tug Subsystems

The concept of Orbital Space Tugs has been a subject of discussions since the 1970s. We believed that it would be interesting to share with you some the concepts that have been looked at over the years and the various configurations evaluated

Optional Configurations

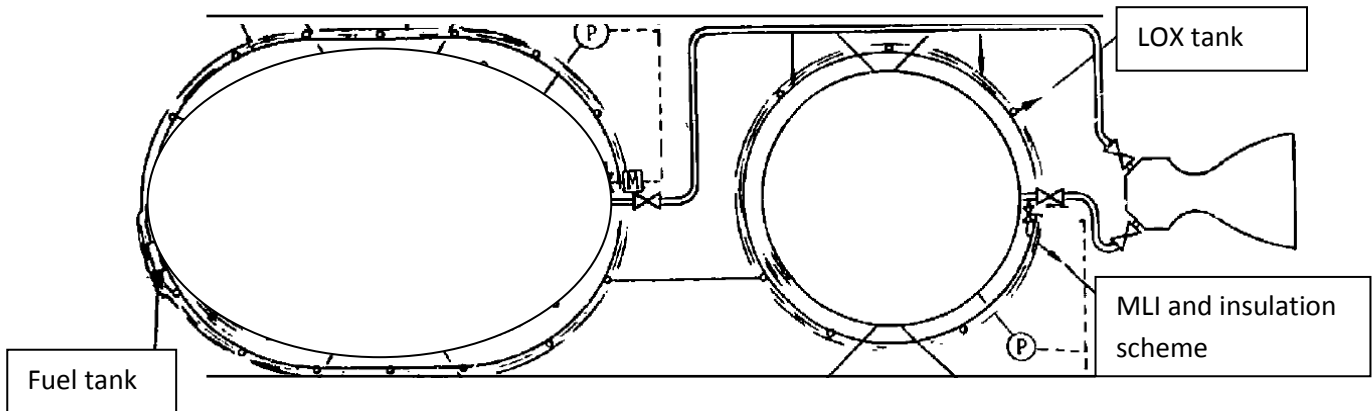

Figure 5 Conventional Propellant Insulated Tank Arrangement.

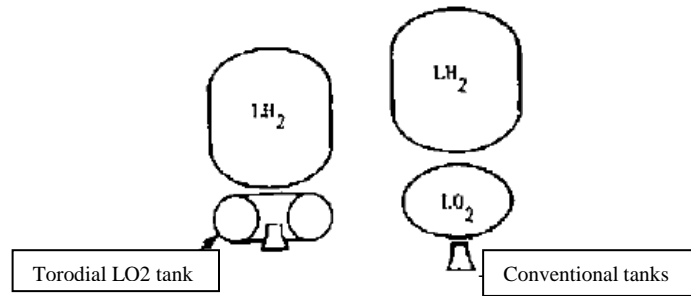

Figure 6. Comparison Conventional vs. Toroidal LOX tank configurations

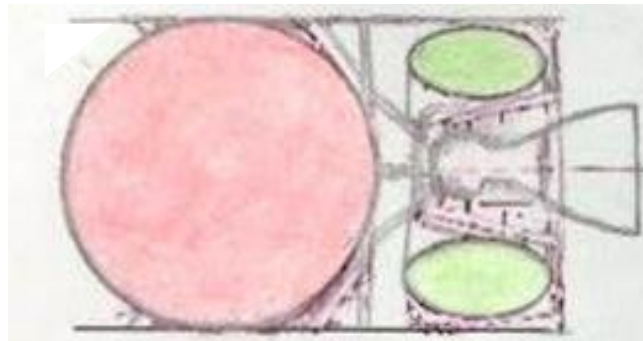

Figure 7. Toroidal LOX tank configuration

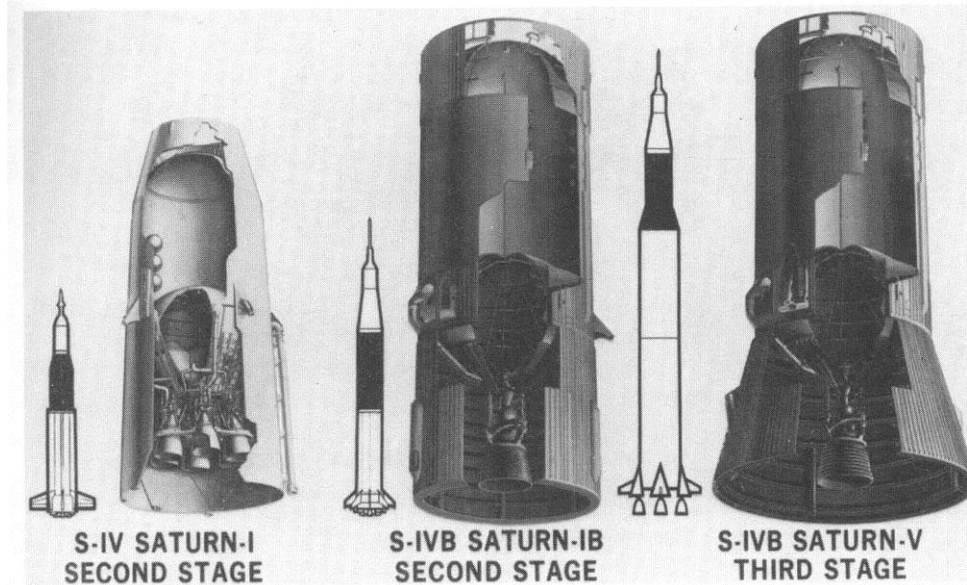

Figure 8. Cutaway drawings compare the S-IV stages on Saturn 1, IB, and V.



Figure 9. S-IV and S-IVB Configurations

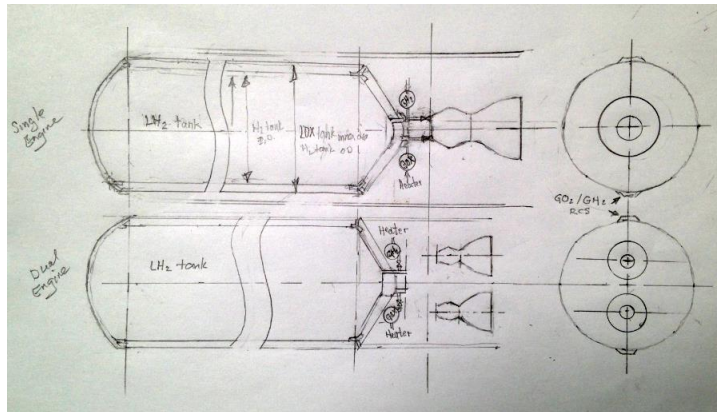

Figure 10. Concentric propellant Tank Configuration



Figure 11. Alternate Space Tug Configuration

In the late 1970s, NASA began investigating space-based reusable systems to provide in-space mobility. One such study was performed by Boeing in 1982, as the second part of an orbit transfer vehicle (OTV) conceptual design study. It focused on reusable OTVs⁽⁶⁾.

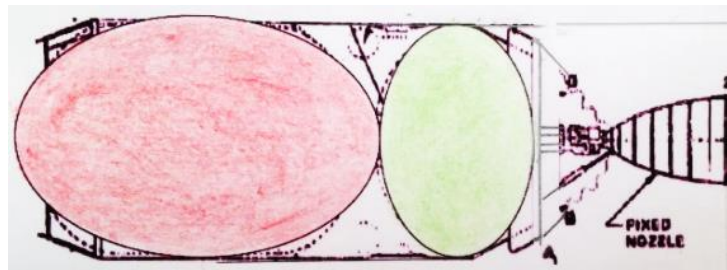

Figure 12. Space-based OTV

The intent in showing these illustrations is to point out the many studies and configuration options employing the RL-10 and J-2 liquid oxygen/liquid hydrogen engines starting with Centaur and Saturn S-I and S-IVB stages. Design solutions have been addressed in a number of forms, and we will show how these can be integrated together to show a viable Space Tug to be developed and put into operation. The many applications going back to the Apollo S-IV on the S-IB; and, more recent tankage studies by Lockheed Martin on the Advanced Common Extended Stage (ACES) and Dual Thrust Axis Lander (DTAL)⁽⁵⁾. Experience with the RL-10 and on-going studies provide a broad source of technical data applicable to the Space Tug LOX/LH₂ propellant selection and the J-2-engine applications which is the thrust class to be considered. The upper stage of both the Saturn S-IB and Saturn V were evolved from the upper stage of the Saturn I. All three stages manufactured by Douglas Aircraft Company used liquid hydrogen and liquid oxygen as propellants, and shared the same basic design concepts and manufacturing techniques.

The Saturn I upper stage (the S-IV) used a cluster of six RL-10 engine and the Saturn IB and Saturn V upper stages (designated S-IVB for both versions) possessed the larger diameter and mounted a single J-2 engines. The S-IVB stage diameter accommodated a 6.6 meter tank. The S-IVB mission posed special requirements on its design. The engine and stage needed the capability to restart in orbit and had to have special equipment to ensure storage of propellants and proper orientation while in Earth orbit. The weight of propellants included 87200 kilograms of LOX and 18000 kilograms of LH₂ (with some variations depending on mission requirements). The volume of the lighter LH₂ was much greater requiring a larger vessel to hold 225750 liters (69500 gallons), as compared with only 73280 liters (20150 gallons) of LOX. System integration issues determined the tank location, If the LH₂ tank were in the aft position with the LOX tank above, LOX feed lines would be longer and would have to run through the interior of the LH₂ tank (with additional problems of insulating the the LOX lines from the colder liquid hydrogen) or longer LOX lines would have to be mounted externally between the LOX lines and the associated hardware. The fuel tank was installed forward with LH₂ feedlines routed around the smaller and more compact oxidizer tank⁽⁷⁾.

Thermal stress was a major concern in S-IV construction and operation. Internal insulation was attractive in terms of thermal stress qualities. Thermal stress was extremely critical in the filling of the rocket's fuel tanks when LH₂ at -253°C (-423°F) came into contact with tank walls at warmer ambient air temperatures. If insulation was external, it was feared that the LH₂ would create severe thermal stress and potential damage to the tank walls as it was pumped in, because the aluminum walls possessed a very high coefficient of expansion. Even if no serious weakening was caused by the first filling, repeated operations could create problems, especially for vehicles undergoing a series of static tests and tankage checks. Internal installation of the S-IV's insulation could eliminate many such problems in

the tank walls. During filling, internal insulation promised dramatic advantages in reducing LH₂ loss through boil-off. When external insulation was used, nearly 100 percent of the tank's capacity had to boil off to bring the temperature of the walls down to -253°C (-423°F) to keep the LH₂ stable. Given the volume of tankage of the S-IV, external insulation meant a need for much greater quantities of expensive propellants and additional paraphernalia to provide a venting system to cope with the furious boil-off. By using internal thermal insulation, on the other hand, it was possible to expect only 25 percent boil-off of the tank's capacity, reducing the mechanical complications and all the other inherent drawbacks. Even with the highly efficient insulation finally developed for the S-IV and S-IVB, an LH₂ tank topped off at 100 percent capacity before launch needed constant replenishment, since the boil-off required compensation at rates up to 1100 liters (300 gallons) per minute.

The thermal design and associated problems must be thoroughly understood before proceeding with the detailed vehicle conceptual design and all the potential problems characterized. The continued use of the J-2 and development improvements with J-2X, etc., established a firm engine technology base for the Space Tug vehicle.

IV. Space Tug Design

The Space Tug is designed for long term space operation and uses technology improvements needed to enable large quantities of cryogenic fluids to be stored in space for periods up to 20 years. The long-term storage of cryogenics in space is important for space-basing of orbit maneuvering vehicles, and space station servicing facilities. The design considers previous studies showing sufficient detail to conceptualize the design requirements. The OMV design details below which apply to the Space Tug design were established in conjunction with the results of previous studies. Major contributors to extended storage life for the OMV were shown to be the thermodynamic vent system (TVS), multilayer insulation and refrigeration. Lesser contributions are obtained with thermal coatings which reduce the bay temperature, Para to Ortho hydrogen conversion; glass over-wrapped pipes and penetrations, and reduced support strut heat leaks.

Some observations:

1. A coupled thermodynamic vent system provides a simple means of achieving long storage life in space;
2. Technologies offering the greatest payoff are improved Multi-layer insulation (thick insulation blankets) for large tankage and long-life TVS components;
3. Direct refrigeration of the cryogen storage tanks offers significant weight and volume advantages and provides the best potential for storage life enhancement. Free-flying experiments to resolve technical issues, verify projections and provide information are needed. These aspects will be considered as we advance from conceptual to detail design of the thermal management scheme to be selected.

A. PROPULSION SYSTEM:

The propulsion system provides primary and maneuvering thrust and houses the primary avionics, electrical power generation and thermal control. Attached to the propulsion system is a universal docking adapter and payload latching/unlocking system at its forward end. This is to be used to attach the architecture elements as they are being assembled, payload retrieval, crew module etc. This interface also includes standard interfaces for the crew module and payload that interconnect power, gases, fluids, thermal control, and data systems: and, the space station in advance of the architecture in-space elements.

The Space Tug housing the propulsion system can be launch with the SLS. Establishing the maximum diameter for the propellant tanks including insulation for the liquid hydrogen and oxygen tanks is critical in setting final requirements for the Space Tug detailed conceptual design. These propellants can enable self-pressurization of the propulsion system and are also fed to separate high pressure GOX/GH₂ tanks for pressurization and reaction control. This reduces the number of propulsion fluids to two by eliminating the need to handle separate tank pressurization gases, such as helium, as well as separate propellants for the reaction control system. These propellant choices also enable the entire propulsion system to be purged by opening the system to the vacuum of space.

Saturn V's S-IVB⁽⁷⁾ has six basic systems: propulsion, flight control, electrical power, instrumentation and telemetry, environmental control, and ordnance. Effective operation of the J-2 engine depended on the ability of S-IVB to manage the supply of liquid oxygen and liquid hydrogen on board. The propulsion system included not only the J-2 engine but also the propellant supply system, a pneumatic control system, and a propellant utilization system (PU system) all of which must be well understood. The LOX propellant tank could take 72 700 liters (20 000 gallons) of liquid oxygen, loaded after a preliminary purge and pre-chill cycle. The fuel tank of the S-IVB carried 229 000 liters (63 000 gallons) of liquid hydrogen.

The pressurization of each propellant tank can be provided with pressurant gas either by an engine heat exchanger or the O₂H₂ burner, which draws oxidizer and fuel directly from the vehicle's LOX and LH₂ tanks. For additional pressurization, the liquid hydrogen tank also used gaseous hydrogen, tapped directly from the J-2 during steady-state operation. The system for tank pressurization and repressurization employed sophisticated techniques and minimum weight. Particularly notable were the special helium storage bottles, made of titanium and charged to about 211 kilograms per square centimeter at -245°C (3000 pounds per square inch at -410°F), and the O₂H₂ helium heater.

The fully loaded LOX tank was kept pressurized with gaseous helium 2.7-2.9 kilograms per square centimeter adiabatic (38-41 pounds per square inch adiabatic) for necessary start of stage-engine operation. The inflight helium supply came from nine helium bottles submerged in the liquid hydrogen tank. During engine operation, a special engine heat exchanger expanded the helium before it was fed into the LOX tank, maintaining required pressures. During the orbital coast phase, pressure decayed in the LOX tank and caused the engine heat exchanger to expand the helium which was not effective until steady-state operation of the engine, an alternative repressurization source was required. This was the function served by the O₂H₂ burner. It was located on the thrust structure and looked very much like a miniature rocket. It did, in fact, have an adjustable exhaust nozzle and generated 71 to 89 newtons (16 to 20 pounds) of thrust, expelled through the stage's center of gravity. To repressurize before a burn, the O₂H₂ burner operated to expand a flow of helium from the nine helium storage spheres. This repressurized the LOX tank. After ignition, the engine heat exchanger once more provided the mechanism for the flow of expanded helium gas.

For the LH₂ tank, initial pressurization came from an external helium source to stabilize tank pressures at 2.2-2.4 kilograms per square centimeter adiabatic (31-34 pounds per square inch adiabatic). When this operational level was reached, the boil-off of LH₂ inside the tank was enough to maintain pressure until the J-2 engine started up. At this point, the fuel propellant pressurization system relied on gaseous hydrogen bled directly from the engine system. During orbital coast, the fuel tank pressure was maintained by LH₂ boil-off, with a special vent-relief system to avoid overpressures. Additional excess pressure was used in a continuous "propulsive vent system," which helped keep the propellants settled toward the bottom of the tank. Like the LOX tank repressurization sequence, the fuel tank repressurization sequence for the each burn relied on the O₂H₂ burner, which repressurized the LH₂ tank simultaneously with the LOX tank. Once the J-2 engine reached steady-state operation, LH₂ pressures reverted back to gaseous hydrogen bled from the engine.

The J-2 engine created one unique problem for the S-IVB stage: the "chilldown" cycle prior to engine start. As part of the propellant system, the S-IVB stage included the chill down sequence to induce cryogenic temperatures in the LOX feed system and J-2 LOX turbopump assembly before both the first J-2 burn and the restart operation in orbit. This process enhanced reliable engine operation and avoided the unwelcome prospect of pump cavitation, which might have caused the engine to run dangerously rough. On command from the instrument unit, a LOX bypass valve opened and an electrical centrifugal pump, mounted in the LOX tank, began to circulate the oxidizer through the feed lines, the turbopump assembly, and back into the main LOX tank. This chill down sequence began ignition and continued through the burn phase, right up to the time of J-2 ignition. The equipment operated again during orbital coast, anticipating the additional burn of the J-2 for the mission operation and a concurrent sequence ensured proper chill down for the LH₂ feed lines and turbopump assembly. The S-II second stage used a similar operation⁽⁷⁾. This would be used to safe the propulsion system before being brought into a LEO space logistics base's space hangar for maintenance. The Space Tug includes provisions for mounting two medium capacity robotic arms to support

materiel handling. These arms will attach to the forward bulkhead of the vehicle. The mass of the arms are sized to handle the 20,000 kg retrieval mass.

Lithium-ion batteries are considered for primary power in the Space Tug to eliminate on-orbit servicing of either a fuel cell system or an externally-deployed solar array system. The combination of the low self-discharge rate of the lithium-ion batteries and the low boil-off rate of the cryogenic propellants will enable the Space Tug to be parked for extended periods of time while being immediately available for operation. This is important for the Space Tug's use in conducting emergency space search and rescue operations. Active thermal management, for internally-generated waste heat, is incorporated into the propulsion module to collect and discharge heat from the avionics, reaction control system, crew module, and electrical power generation and distribution. Waste heat, collected through cold plates and air-to-water heat exchangers, can be eliminated through external radiators.

B. SHIELDING AND INSULATION

Externally-mounted micrometeoroid and space debris shields and multi-layer insulation to control solar heating will be considered. Micrometeoroid/debris shielding is provided through a stand-off-mounted aluminum shell, referred to as a bumper; that, serves to cause impacting micrometeoroids and debris to break-up and vaporize. Multi-layer insulation and thermodynamic vent system, located under the bumper to control external heating from solar radiation, will be evaluated to assist in limiting penetration of small micrometeoroids and debris.

C. IDEAL SPACE TUG PERFORMANCE

The Space Tug being a reusable in-space based vehicle is not so sensitive to weight as systems which are reusable and require repeated earth launch. However, minimum dry weight is still an important factor but secondary importance to flight performance. Design studies indicate that propellant fractions much above approximately 85 percent are not readily achievable for lower density cryogenic fuels and the performance needed. The hydrogen-oxygen engine does provide the needed performance at achievable propellant fractions.

D. POINT DESIGN DATA

The conceptual design of the Space Tug will have a propulsion system comparable to the S-IVB stage of the Saturn vehicle and will have an equipment bay on the aft of propellant tanks; a forward compartment for in-space component testing; and , docking adaptor compatible with the space station and Orion vehicle. The Space Tug vehicle will also incorporate the necessary features to carry two robotic arms to provide mission assistance such as manipulating payloads.

E. PROPULSION SYSTEM CONCEPTUAL DESIGN

The main propulsion engines utilize all the knowledge gain through the use of the RL-10 and J-2 families of engines which have been demonstrated successfully on many upper stages, including J2-X and RS-68 engines.

F. ESTIMATED MISSION PERFORMANCE AND SYSTEM MASS ESTIMATES

The mission performance and system mass estimates will be similar to missions listed below, however cannot be quantified until the detailed conceptual design has been completed. The propulsion system will be comparable to the S-IVB stage. Sample missions are presented below from previous studies will have to be developed in establishing the mission requirements for the Space Tug. These are only shown to give an understanding of what needs to be developed to establish tug requirements

1. Mission 1- carrying the payload of the crew module, two robotic arms, and a mission kit of 1,000 kg,. This yielded a space ferry with a mission gross weight of 57,900 kg (127,700 lb) and an empty mass (including crew module, robotic arms, and mission kit) of 13,350 kg (29,400 lb). The propulsion module empty mass was 6,400 kg (14,100 lb).
2. Roundtrip mission from LEO@28.5° to/from GEO have one of largest mission ΔV requirements. A mission of interest is the extension of this mission to delivery cargo to the Earth-Moon L1 point, perhaps to support a permanent human presence on the Moon. Adjusting the mission ΔV , including the use of aerobraking, can yield increase in the delivered payload to approximately 20,500 kg (45,200 lb).

3. Another mission of interest is the extension of Mission 1 to perform a manned servicing mission to a scientific platform located at the Earth-Moon L-2 point. The servicing mission kit mass—in addition to the crew module and robotic arms—is 9,500 kg (20,950 lb).

V. SPACE BASED SPACE TUG VEHICLE

OVERALL PROPULSION FUNCTION

The Space Tug is designed to support future in-space architecture elements and missions to send spacecraft to the MOON, ASTEROID and MARS both unmanned and manned. The overall function is to:

- (1) Provide Orbital Maneuvering Propulsion (insertion/circularization, de-orbit & Trans-lunar/mars injection) and provide for the following functions: fill & drain; on-board propellant storage; cryogenic on-board propellant and hardware conditioning for engine start; storable propellant conditioning for engine start; on-board purge; pressurization; tank feed; fluid pump/pressure transfer; combustion; propellant inlet/intake management; nozzle exhaust gas management; propellant management (residuals, fuel bias, margins); engine start; engine shutdown; propellant flow and thrust interaction control (pogo suppression); anti-geysering control; propellant acquisition/settling; propellant/hardware thermal management; engine control & health management; propulsion power generation; and hardware contamination/flush for start/restart.
- (2) Provide Reaction Control Propulsion and provide for the following functions: fill & drain; on-board propellant storage; cryogenic on-board propellant and hardware conditioning for engine start; storable propellant conditioning for engine start; on-board purge; pressurization; tank feed; fluid pump/pressure transfer; combustion; propellant inlet/intake management; nozzle exhaust gas management; propellant management (residuals, fuel bias, margins); nozzle exhaust gas management; propellant management (residuals, fuel bias, margins); engine start; engine shutdown; propellant flow and thrust interaction control (pogo suppression); anti-geysering control; propellant acquisition/settling; propellant/hardware thermal management; engine control & health management; propulsion power generation; and hardware contamination/flush for start/restart.
- (3) Provide element separation propulsion and provide for the following functions: fill & drain; on-board propellant storage; cryogenic on-board propellant and hardware conditioning for engine start; storable propellant conditioning for engine start; on-board purge; pressurization; tank feed; fluid pump/pressure transfer; combustion; propellant inlet/intake management; nozzle exhaust gas management; propellant management (residuals, fuel bias, margins); nozzle exhaust gas management; propellant management (residuals, fuel bias, margins); engine start; engine shutdown; propellant flow and thrust interaction control (pogo suppression); anti-geysering control; propellant acquisition/settling; propellant/hardware thermal management; engine control & health management; propulsion power generation; and hardware contamination/flush for start/restart.

PROPULSION SYSTEM CHOICES

The first order effects of a number of propulsion system and related subsystem choices have been evaluated to help users assess the preliminary impact of these choices on architectures. A review of these general space launch vehicle, spacecraft propulsion, thermal, and power related subsystem attributes will be performed when conceptualizing any new or derivative system. Also, the Technology Readiness Level (the measure of design maturity) and the design risk (in cost and schedule) must be carefully considered for each design choice. Then the actual selection of various subsystem elements and approaches must be optimized at the overall systems level using

a tool that allows focus on multiple attributes and not only one attribute (such as, engine-specific performance or weight). Otherwise the engine may be optimized, but at the expense of the system. Reviewing this “design-guide” and implementing the optimum set of systems will lead to the Space Tug vehicle design with the optimum combination of the propulsion, thermal, and power systems that can reduce lifecycle cost and overall system operational risk. Some references are provided below that provide additional details on the characteristics and attributes of the design elements described in this paper.

SELECTED SPACE TUG DESIGN CHARACTERISTICS

Key Requirements

- (1) Long Term Space based Multi-Purpose Space Tug Vehicle
- (2) 20 year life with refueling in space
- (3) Maximize dormant life without re-fueling (Goal of 5 years)
- (4) Minimum fluids and pressurant types required
- (5) In-space upgrade capability for engines, power and control
- (6) Ability to carry two robotic arms
- (7) Electrical power and thermal management capabilities to support the crew module, robotic arms, and payloads requiring electrical power and thermal management, as appropriate for the mission.
- (8) Vehicle equipment and avionics bays to permit the crew module to be attached to the top of the Space Tug using a universal docking adapter.
- (9) Fairing around the top of the engine installation for increased micrometeoroid and space debris protection.

Space Tug Mission Capabilities

Establishing the need to accomplish the missions cited based on the vehicle concepts to support the missions and needs discussed in Appendix 3⁽⁷⁾ are advanced power systems and advanced space engines both essential to the Space Tug. These requirements were defined for post 2000 needs to follow and still remain key today. This vehicle represents an early introduction of the in-space architecture that must be put in place for man to begin his journey in space as described in the series of papers on “Roadmap for Long Term Sustainable Space Exploration and Habitation⁽²⁾ and provide an early development of long life in-space hardware needed; and, begin qualifying essential hardware in advance major funding needed. Budget and political environment have prohibited progress with this essential endeavor for all mankind. Some missions and operations to be performed are summarized below:

Primary:

- (1) Retrieval of LEO objects and move to new orbits
- (2) Retrieval of Higher Orbit objects and move to lower orbit
- (3) Enable Space Based Enterprise by providing transportation support for re-supply, etc.
- (4) Docking capability with Space Station
- (5) Establish in-space propellant transfer
- (6) Upgraded major key in-space hardware, i.e. engines, power, etc.

Secondary:

- (1) Hardware demonstration for long term in-space use
- (2) Qualify long term in space critical hardware

Technology Needs

Pursuit of new technology is important, so too is the exploration and further refinement of existing technology as described in the NASA/DOD Space Launch Study ⁽⁸⁾. A response to NSDG, National Space Launch Strategy, using

existing technology in new ways and using previous extensive national investments, such as Space Shuttle with advanced cryogenic engines (or its replacement) and the capabilities of the space station, may provide cost effective solutions for meeting future requirements.

The flight control system gave the S-IVB stage its attitude control and thrust vector steering from correction signals originating in the instrument unit. The vehicle was steered by hydraulic actuator assemblies that gimballed the J-2 engine. The hydraulic equipment included both electric and engine-driven pumps, as well as an auxiliary pump. When Douglas began design work on the S-IV actuators, the company developed a unit that was slim and long, very similar to the actuators that Douglas had perfected for landing gear in airplanes. The Huntsville design group, relying on their past experience with the Redstone and other rockets, argued that thrust levels and mission environment of the S-IV called for shorter, thicker actuators. Sure enough, the Douglas actuators developed some unacceptable instability and actuators had to be built to new specifications. We plan to eliminate all hydraulics and additional fluids which will make this a critical sub-system requiring advanced technology needs.

Propulsion System Description

The Space Tug conceptual design will baseline 83000 gallons of total propellants as used on the S-IVB stage. A fifteen percent uncertainty margin will be applied to the dry mass of the propulsion system.

Description of key propulsion sub-systems selected for the Multi-purpose Space Tug Vehicle is described below.

Propellants, Fluids, Pressurization and Control

Liquid Oxygen (LOX) and liquid hydrogen (LH₂) have been selected as the main propulsion system propellants and there are many good reasons for this selection as summarized below:

- (1) Clean non-invasive exhaust products which are becoming a major concern as environmental issues may become prohibitive as we contaminate near earth space.
- (2) LOX/LH₂ provides the highest performance propellant combination for in-space operation.
- (3) Vehicle weight is not a critical factor for efficient in-space based vehicle operation.
- (4) Utilization of gaseous oxygen (GOX) and gaseous hydrogen (GH₂) allowing the use of the main propellants (LOX and LH₂) to operate the Reaction Control System (RCS) thru separate high pressure bottles, as well the pressurization system, which is key to minimizing resupply and servicing issues by reducing required fluids and secondary gases for control functions' This greatly reduces services and life cycle cost at a weight expense not penalized by in-space based vehicles.
- (5) Main tankage pressurization with heated high pressure gas and GOX/GH₂ RCS both supplied from main propellant tanks.
- (6) Propellant Utilization system to assure that both propellant tanks run dry at the same time so as not to compromise mission performance. Its primary function: "to assure simultaneous depletion of propellants by controlling the LOX flow rate of the J-2 engine." With a PU probe located in both the LOX and LH₂ tanks during propellant loading operations, the system also provided information about the propellant mass accumulating aboard the stage. Residual amounts left in either of the tanks would subtract from the accuracy and stability of a desired trajectory or orbit

- (7) Use of electronic actuation to eliminate the need for pneumatic gas such as helium or nitrogen for control operations as currently use on convention propulsion systems.
- (8) Many general reasons and advantages of a common LOX/LH2 propellant combination for all the vehicle fluid requirements. They are readily available, relatively inexpensive, easily handled / existing procedures, environmentally acceptable; and, LOX / LH2 provides the highest level of performance of any commonly used propellant combinations.
- (9) LOX/LH2 are the only propellants that can be integrated not only for all propulsion functions but can also be used for life support and thermal management.
- (10) LOX/LH2 availability and storage procedures have become routine and logistics are in place for their use, thus allowing easy transition to any future launch system.
- (11) Operation concerns that seriously effect operational efficiency is the multiplicity of components and corresponding large number of interfaces require extensive leak check of components and between components.
- (12) Large parts inventories and numerous procedures for parts replacement add to the extensive operations and support requirements. In addition reliability reduced by the many intricate parts.
- (13) Propellant tank pressurization systems requiring engine-supplied tanks should be eliminated. This elimination is the result of a two-fold concern. The first concern is associated with tank pressurization, such as heat exchangers, control valves, and long tubing runs, which require significant amounts of maintenance and checkout. Leak checks of these systems are typically the most complex of the whole vehicle. The second and more important reason for eliminating pneumatic systems is the safety aspect. The Space Shuttle oxidizer heat exchanger has been characterized to contain several potential Class-1 failure modes. Class-1 failure modes are those which could cause loss of crew and vehicle. This is why we are using electronics for controls.
- (14) An operationally efficient vehicle should reduce parts count and eliminate those tasks associated with handling and servicing the numerous components.

THERMAL ENERGY MANAGEMENT

Provide thermal management (heating & cooling) from earth orbit to destination within delta-v capability or during return and provide for the following functions: thermal energy supply (source); thermal energy transport/management within the element; thermal energy storage/accumulation to capture peak loads; thermal energy transport/distribution to user/disposition functions; and thermal energy use or dissipation. The only aspect of thermal management that is treated in this paper is the thermal management for the propulsion system. The subjects treated herein are the propellant tanks and engines. Options, issues and definition of key requirements to work in the thermal management area include the following

1. Avionic - Based on various studies. .
2. Structure - Based on percent of Loaded weight
3. Active Thermal Control – vapor cooled sheild surface area and material thickness estimated
4. Electrical - including Power Lines, Truss work for supporting black boxes instrumentation, and Separation equipment.-.

Propellant tank and thermal control

Existing cryogenic propulsion systems have reduced storage space with single LOX and LH2 tanks allowing minimum tank surface area and penetrations enabling the inevitable tank heating to be positively controlled. The configuration we selected is a further step in containment by utilizing complete concentric tanks thermally protecting the LH2 tank with the LOX tank; and again the weight penalty is limited by the space based nature of the Space Tug Vehicle. The long term storage properly insulated should survive for 4 year life and we believe with current materials and insulation techniques that we can achieve a 5 year design life without refueling. Issues to work include:

1. Propellant Feed
2. System Tank Supports
3. Pressurization Vent System
4. System Tank Supports -

Engine System

Various engine options and cycles were reviewed and the J2-X engine cycle is selected providing self sustaining engine subsystem elements and minimum interfaces with the feed system and desired high performance. Issues considered include a large area ratio nozzle and long term durable chamber pressure to achieve maximum engine performance drove the selection.

Engine features are summarized below:

1. Engine Supports - Engine mass include Gimbal actuators. RL-10 D and J-2 transient data
2. Margin - Estimated on percent of usable - performance reserve
3. Maximum H2 - Based on minimum impulse required at established rate of Boil-off

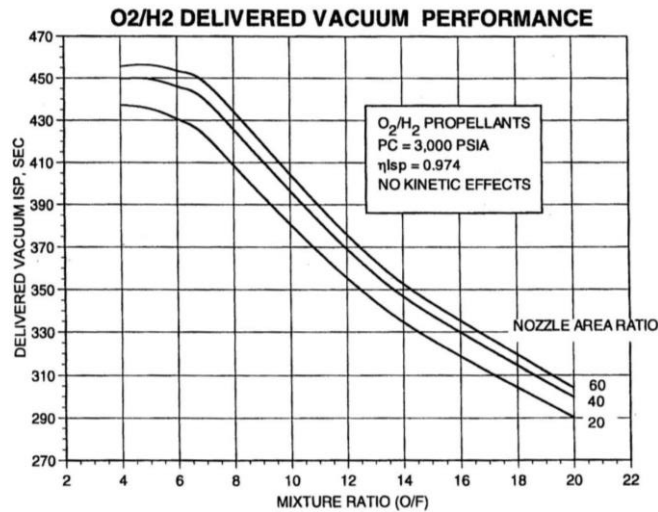

Figure 14 Liquid Oxygen/Liquid Hydrogen delivered vacuum performance

Space Tug Vehicle Conceptual Configuration

A conceptual sketch for the space based Space Tug Multi-Purpose Vehicle is illustrated below:

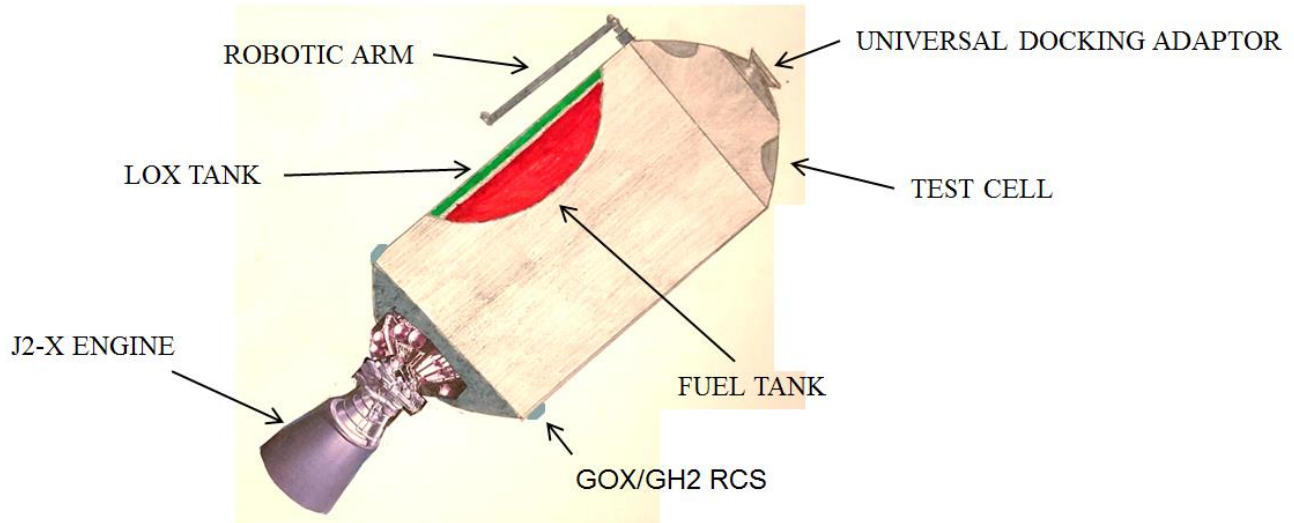

Figure 15 Multi-purpose Space Tug Vehicle Illustration

The configuration consists of concentric propellant tanks with the oxidizer tank housed on the outside to assist in the long term storage requirement; J2-X rocket engine; universal docking adaptor; and a test cell to demonstrate long term operation in space for critical components. The active thermal management system, reaction control system, power distribution system, wiring, fuel controls, and main engines will be fully redundant. The avionics will be triply redundant. The Space Tug vehicle will include provisions for mounting two robotic arms that will attach to the forward bulkhead to support material handling. Externally mounted micrometeoroid and space debris will shield and multi-layer insulation to control solar heating will be considered.

OPERATIONAL SUMMARY

The ground node and the spaced based reusable flight elements requirements have been identified and it seems logical that this effort would be the next near term tasks for developing the human habitation of space to allow the affordable exploration of space. This capability will provide the infrastructure necessary for the commercial expansion of space activities that will close the business case. The requirements are quite extensive and the purpose of providing the Space Tug is to support all the architecture elements as they evolve and begin early implementation of the extensive requirements to follow. The Space Tug will be a working vehicle, and also, provide a component test area to qualify in-space critical components needing qualification in a long term space environment. In space propellant transfer is a critical technology and we intend to maintain the Space Tug in continual operation for many years with docking provisions to the space station for maintenance and servicing on-orbit until new architecture elements which will provide permanent in-space services are established.

The results of the conceptual design analyses indicate that the Space Tug can be developed using current technologies and operational deployment will provide substantial improvement in mobility and logistics servicing and support throughout the Earth-Moon system. The space based tug is an infrastructure element that is paramount to encouraging commercialization in space. This capability will provide the missing element necessary to close the business cases on several applications such as satellite servicing, space debris removal, solar power for earth and space applications, and mining the moon or the asteroids.

VI. Conclusions

Critical to the execution of the NASA Technology Roadmap, is the deep understanding of the past accomplishments in the selected roadmaps, current state of the art within those areas, and the identification of concentrated efforts that should be applied to produce elements enabling the visions of those roadmaps. We have addressed some of the accomplishments and current state of the art technology needed for the In-space Multi-purpose Space Tug Vehicle; and, provided necessary resources needed to quickly and efficiently develops a usable, long-lived, Multi-Purpose Space Tug. While similar vehicles have been discussed in the aerospace literature for many decades, this paper provides sufficient data to define the Space Tug to support the development of the future exclusive in-space based architecture; provide an early test bed to demonstrate and qualify flight critical hardware; and, establish routine space operations throughout the Earth-Moon system. The results of the conceptual design analyses indicate that the Space Tug can be developed using current technologies and operational deployment will provide substantial improvement in mobility, logistics, servicing and provide in-space support throughout the Earth-Moon system. Data collected will be used for establishing a detailed design concept for the Multi-Purpose Space Tug Vehicle.

REFERENCES:

- ⁽¹⁾Claude Joyner II, Daniel Levack, Russell Rhodes, John Robinson, "Propulsion System Choices and Their Implications", 46th AIAA/ASME/SAE/ASEE Joint Propulsion Conference & Exhibit, July, 2010.
- ⁽²⁾Edward Henderson, Russel E. Rhodes, John W. Robinson, Long Term Space Objectives Using Optional Roadmaps (AIAA 2013-3801), 49th AIAA/ASME/SAE/ASEE Joint Propulsion Conference, 2013.
- ⁽³⁾Edgar Zapata, Russell Rhodes, John Robinson, "Vehicle/Propulsion Life Cycle Cost Lessons Learned", AIAA-2010-6504, 46th AIAA/ASM E/SAE/ASEE Joint Propulsion Conference & Exhibit. .
- ⁽⁴⁾John W. Robinson, Carey M. McCleskey, Russel E. Rhodes, Roger Lepsch, Timothy T. Chen, Claude R. Joyner, Daniel J. Levack, "Advanced Space Transportation Concepts and Propulsion Technologies for a New Delivery Paradigm", AIAA 2013-3803, 49th AIAA/ASME/SAE/ASEE Joint Propulsion Conference, July 2013,
- ⁽⁵⁾Kutter. B.F. etal, "Robust Lunar Exploration Using as Efficient Lunar Lander Derived from Existing Upper Stages", AIAA-2009-6566,45th AIAA/ASME/SAE/ASEE Joint Propulsion Conference, July 2009.
- ⁽⁶⁾Snead,J.M., Hellman, B.H.,"Near Future Reusable Space Logistics Vehicle",AIAA-2007-5847, 43rd AIAA/ASME/SAE/ASEE Joint Propulsion Conference & Exhibit, 8-11 July 2007, Cincinnati, Ohio.
- ⁽⁷⁾NASA "Stages to Saturn", SP-4206
- ⁽⁸⁾. NASA /DOD space Launch Technology Study, response to NSDD-144 National Space Strategy
- ⁽⁹⁾.Robinson, J.W., Rhodes, R.E., Henderson, E.M., "Mostly-Reusable LOX/H2 Space Transportation Concept Enabled through Advanced Technology", 50th AIAA/ASME/SAE/ASEE Joint Propulsion Conference, 28-30 July 2014, Cleveland, Ohio.